

Applied Thermodynamics - II

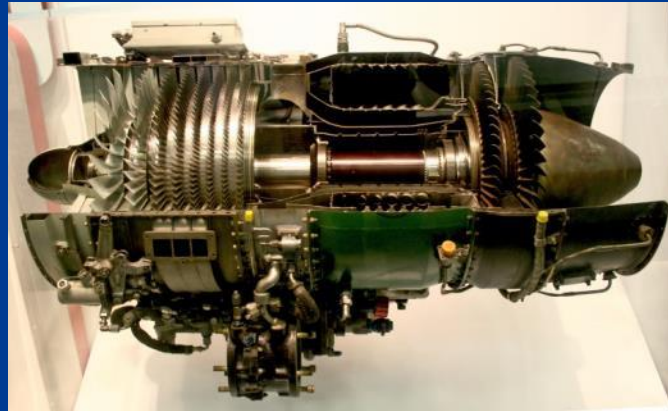

Gas Turbines – Jet Propulsion Cycles

Sudheer Siddapureddy

sudheer@iitp.ac.in

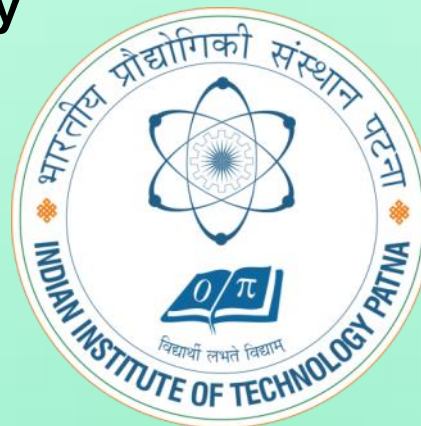

Department of Mechanical Engineering

- Jet propulsion is produced, *wholly* (turbojet) or *partially* (turboprop), as a result of expansion of gas in a propelling nozzle
- Effect of forward speed and altitude on the performance of propulsion engines
- Application of Newton's laws of motion
- Any working fluid can be used

1. A heated and compressed atmospheric air, mixed with products of combustion, air temperature rises to the desired value.
 - Thermal jet
 - **Air breathing engines**
2. Fuel and oxidizer are carried with the system itself, fuel-oxidant mixture is propellant.
 - No air is used. Jet is *Rocket jet*, the equipment wherein the chemical reaction takes place is *Rocket motor*
 - **Rocket engine**

Net thrust = Momentum thrust + Pressure thrust

$$F = m(C_j - C_a) + A_j(P_j - P_a)$$

mC_j is gross momentum thrust

mC_a is intake momentum drag

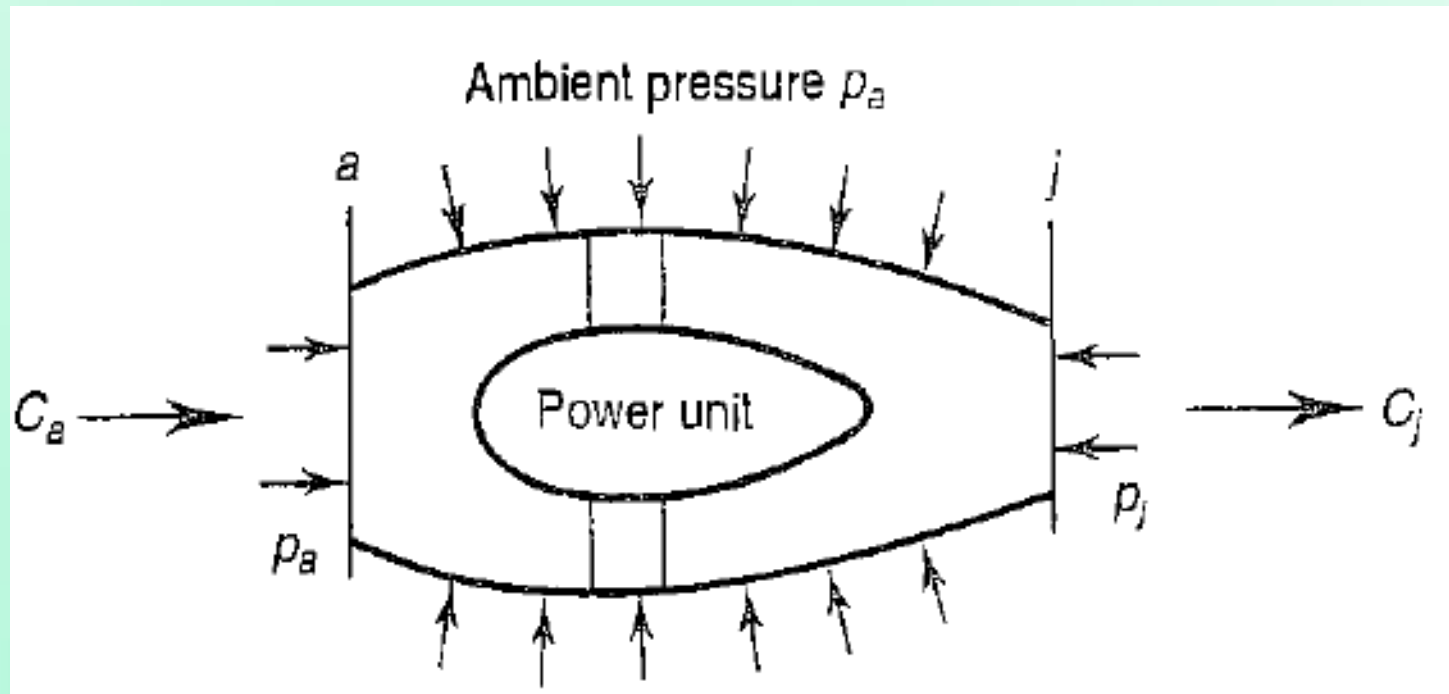

Ratio of the useful propulsive energy or thrust power (FC_a) to the sum of that energy and the unused kinetic energy of the jet

The unused KE of the jet relative to the earth is $m(C_j - C_a)^2/2$

$$\eta_p = \frac{mC_a(C_j - C_a)}{mC_a(C_j - C_a) + m(C_j - C_a)^2/2}$$

$$\eta_p = \frac{2}{1 + C_j/C_a}$$

- F is maximum for $C_a = 0$ (static conditions), but $\eta_p = 0$
- η_p is maximum for $C_j/C_a = 1$, but $F = 0$

$$C_j > C_a$$

In the order of increasing mass flow and decreasing jet velocity:

1. Ramjet engine
 2. Pulse jet engine
 3. Turbojet engine
 4. Turboprop engine
- Higher cruising speed for ramjet while lower for turbojet
 - Selection depends on: Cruising speed, desired range of the aircraft and maximum rate of climb

Another classification:

- A. Pilotless operation (1, 2)
- B. Piloted operation (3, 4)

Classification

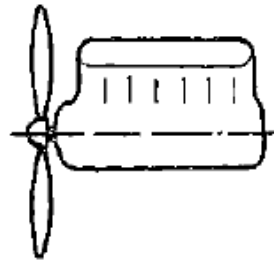

(a) Piston engine

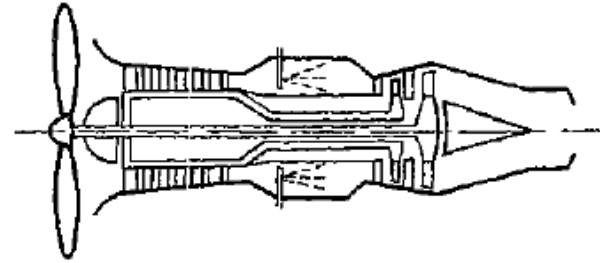

(b) Turboprop engine

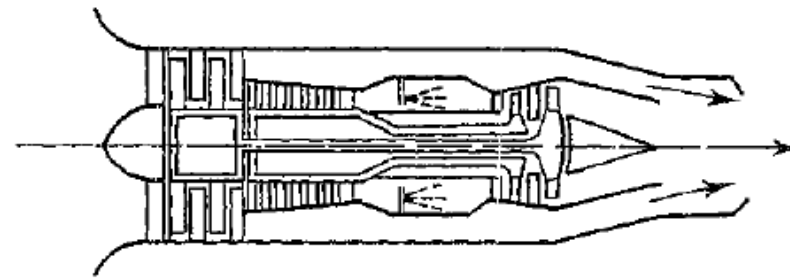

(c) Turbofan engine

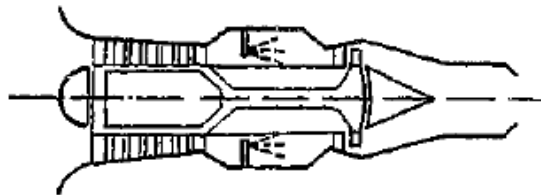

(d) Turbojet engine



(e) Ramjet engine

Classification

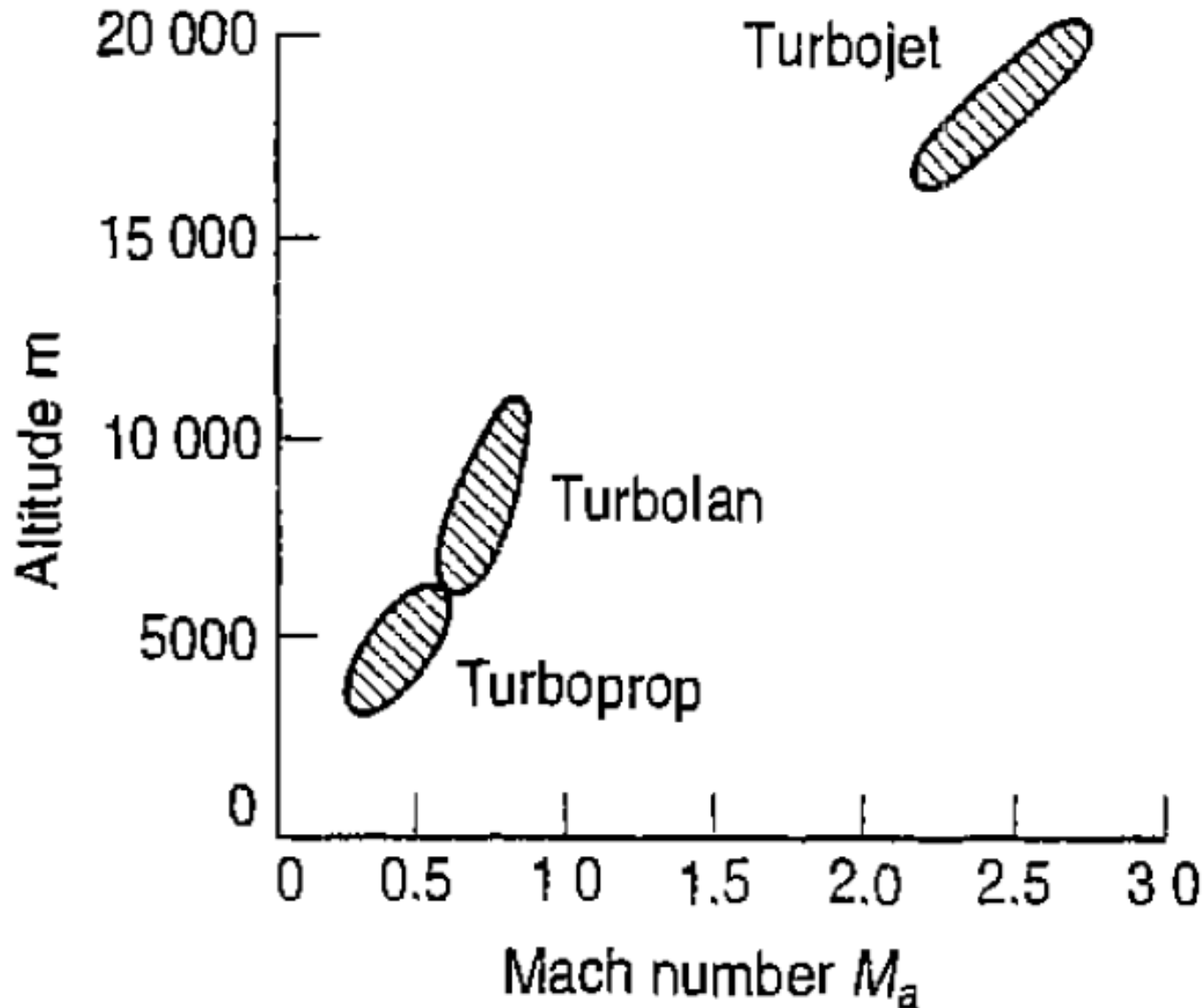

The rate of energy supplied in the fuel ($m_f Q_{net}$) is converted into:

potentially useful KE for propulsion $m(C_j^2 - C_a^2)/2$

together with unusable enthalpy in the jet $mC_p(T_j - T_a)$

$$\eta_e = \frac{m(C_j^2 - C_a^2)/2}{m_f Q_{net}}$$

Overall efficiency is the ratio of the useful work done in overcoming drag to the energy in the fuel supplied:

$$\eta_o = \frac{m C_a (C_j - C_a)}{m_f Q_{net}} = \frac{F C_a}{m_f Q_{net}}$$

$$\eta_o = \eta_p \eta_e$$

η of an aircraft is inextricably linked to the aircraft speed

SFC for an aircraft engine is the fuel consumption per unit thrust (kg/h N)

$$SFC = \frac{m_f}{F}$$

$$\eta_o = \frac{C_a}{SFC} \frac{1}{Q_{net}}$$

With a given fuel, the value of Q_{net} is constant.

$\eta_o \propto C_a/SFC$ while it is $1/SFC$ for shaft power units

Specific thrust is the thrust per unit mass flow of air (Ns/kg)

$$F_s = \frac{F}{m_a}$$

$$SFC = \frac{f}{F_s}$$

Ramjet Engine



1. Supersonic diffuser (1-2)
2. Subsonic diffuser section (2-3)
3. Combustion chamber (3-4)
4. Discharge nozzle section (4-5)

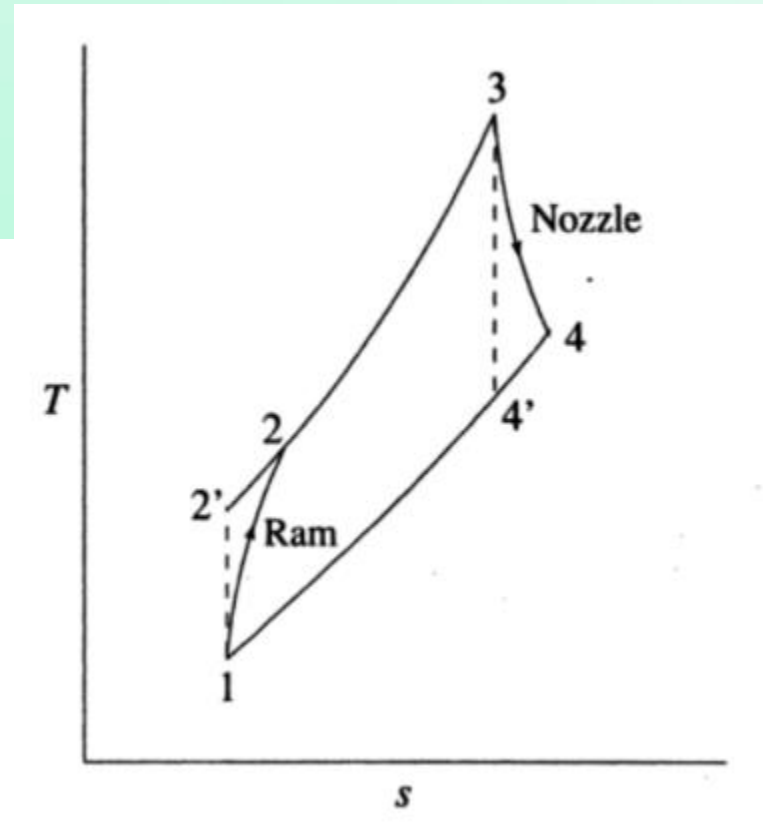
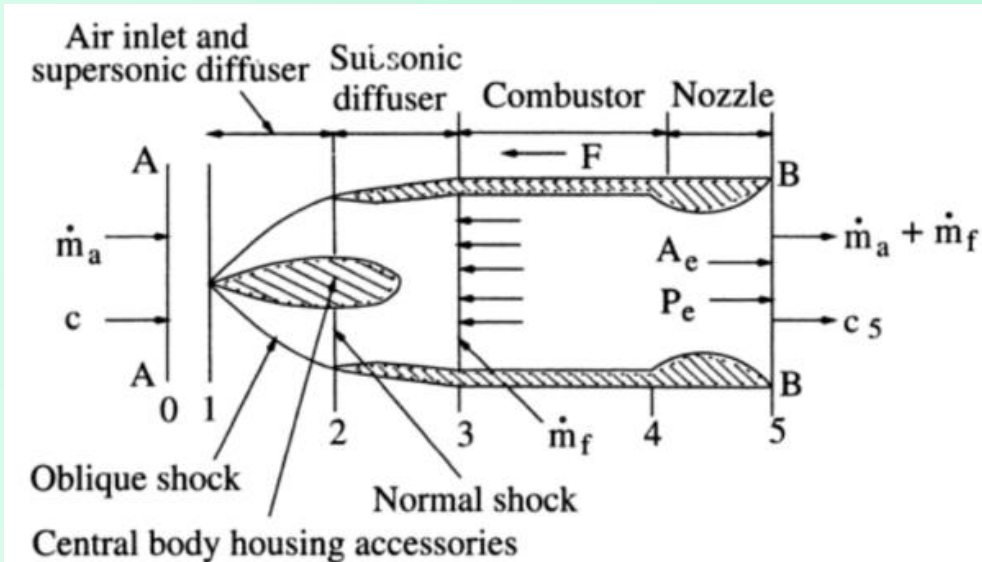

Ramjet Engine - Performance

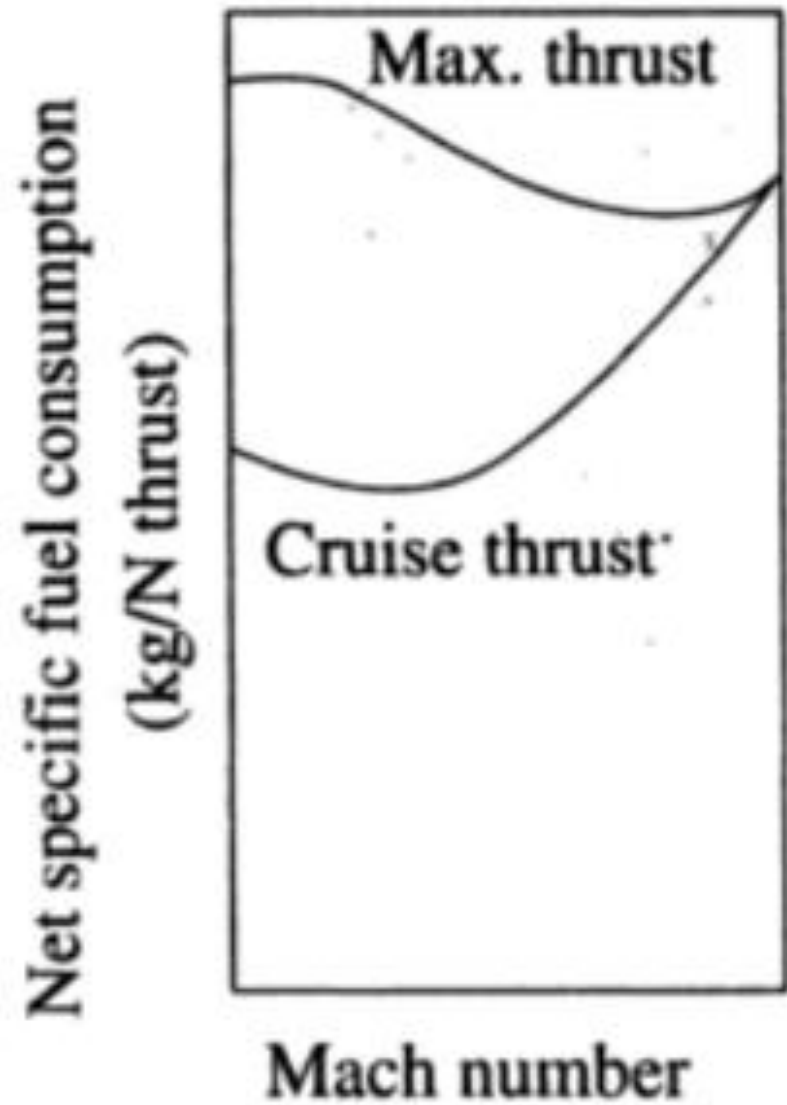
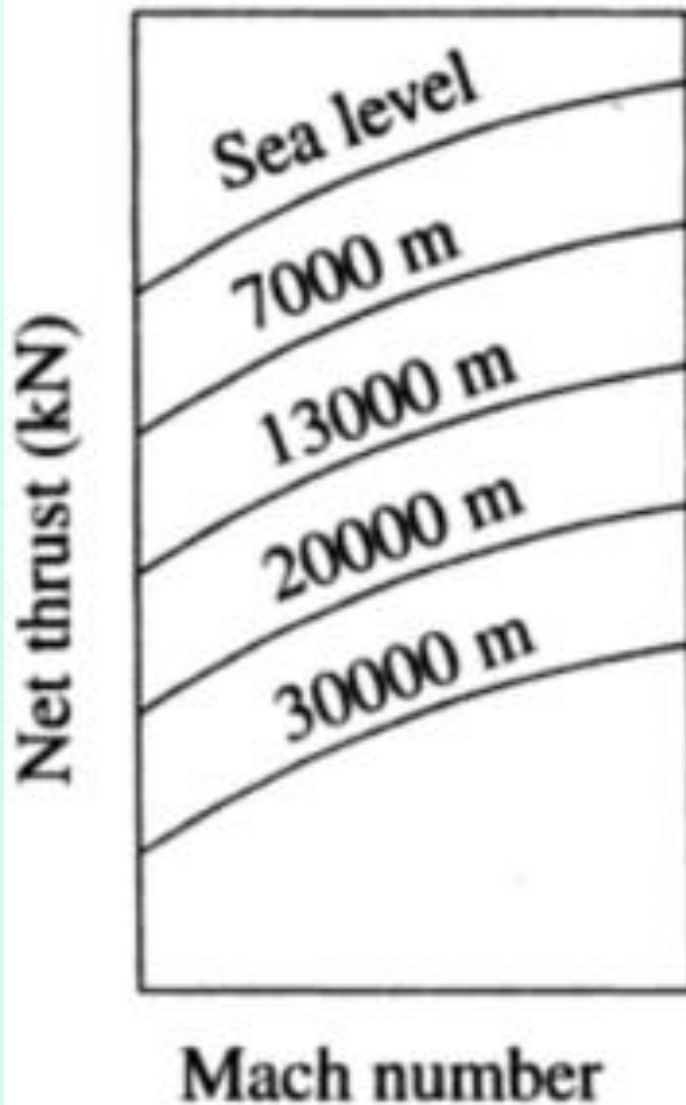

Advantages

1. No moving parts, no maintenance
2. No turbine, $T_{max} = 2000^{\circ}\text{C}$
3. Greater thrust with $1/f = 13:1$
4. *SFC* is better than other gas turbine power plants at high speed and high altitudes
5. Theoretically no upper limit on the flight speed

Disadvantages

1. Take-off thrust is zero. Needs external launching device
2. Engine relies on diffuser and designing one with good pressure recovery over a wide range of speeds is very difficult
3. High air speed, CC requires flame holder
4. At very high T dissociation of products of combustion occurs reducing η of the plant if not required during expansion

1. Simple engine and easy for mass production, cheap
2. Even solid fuels can be used
3. Fuel consumption is very large for aircraft propulsion or in missiles at low and moderate speeds
4. Fuel consumption decreases with flight speed and approaches a reasonable value at $2 < M < 5$
5. Suitable for propelling supersonic missiles
6. Widely used in high-speed military aircrafts and missiles

Pulse Jet Engine



Pulse jet was the power plant of German V-1 bomb popularly known as 'Buzz Bomb' first used in World War II in 1944

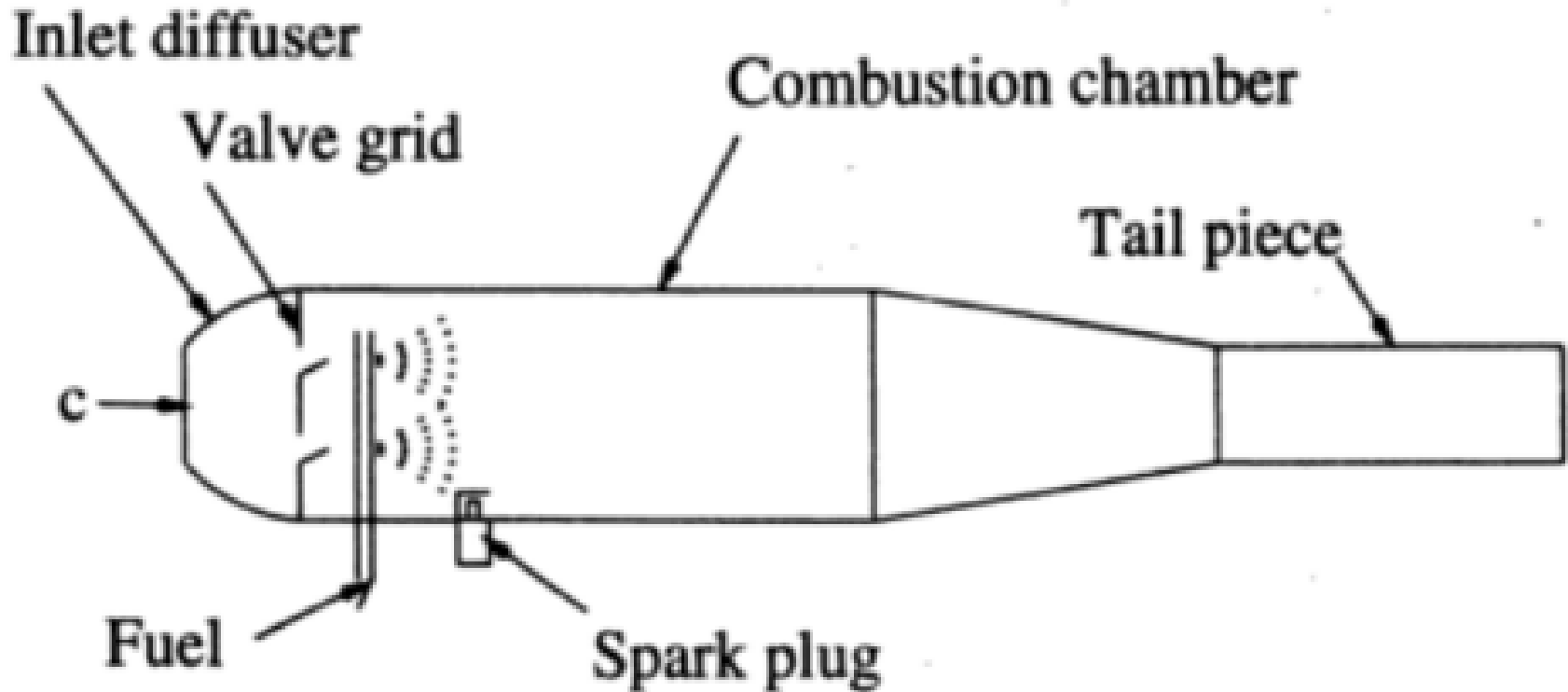

Jet Propulsion - Ramjet

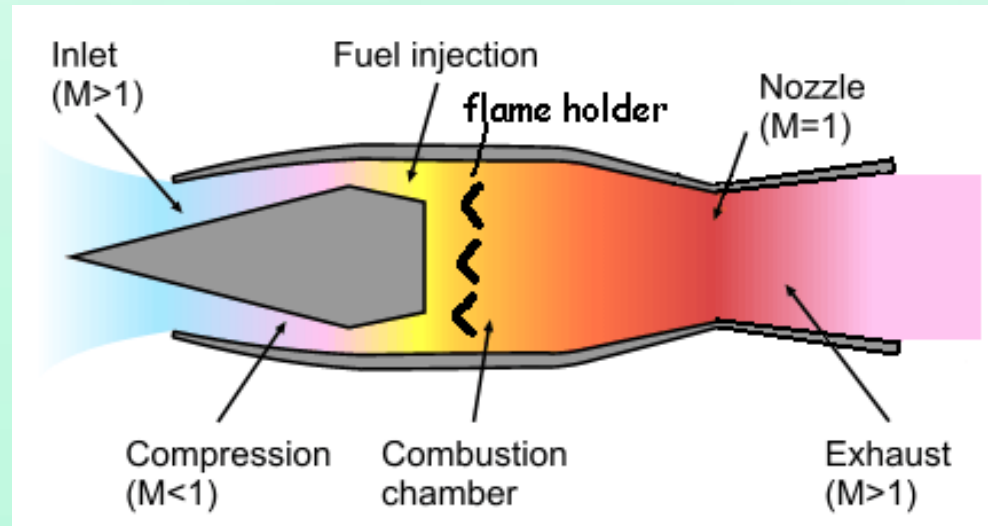

Jet Propulsion - Turbojet

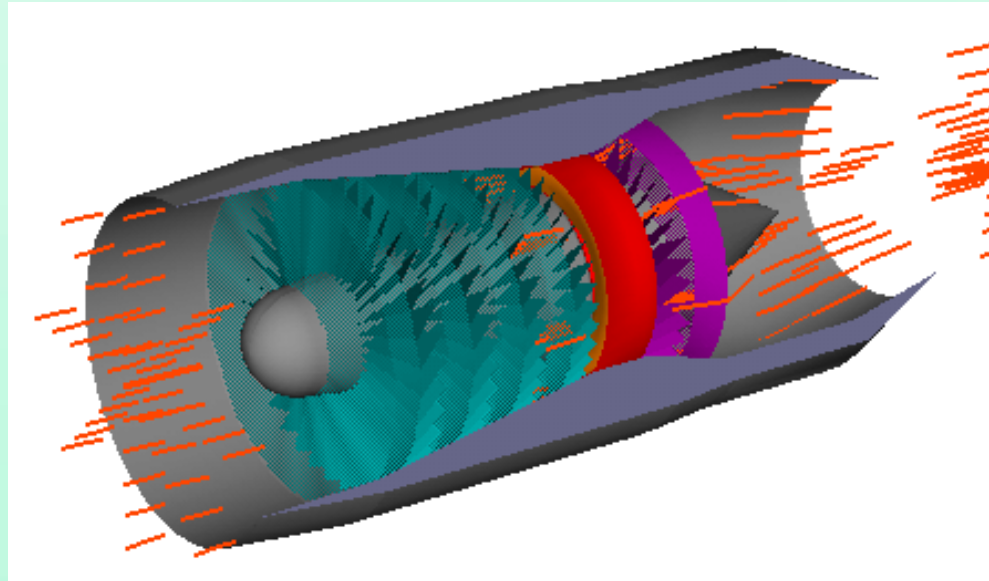

Jet Propulsion - Turbofan

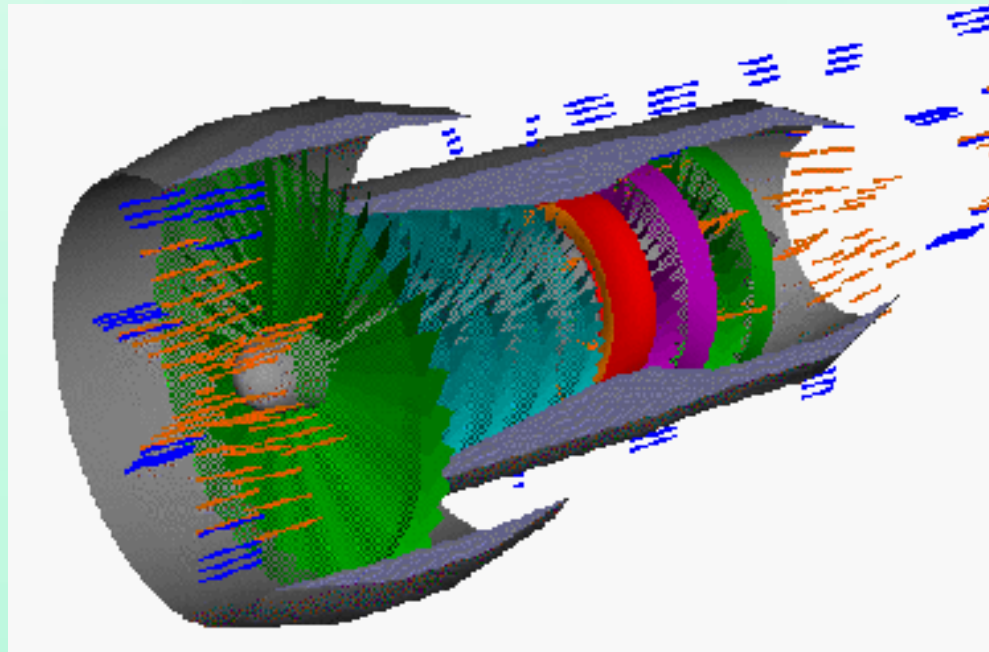

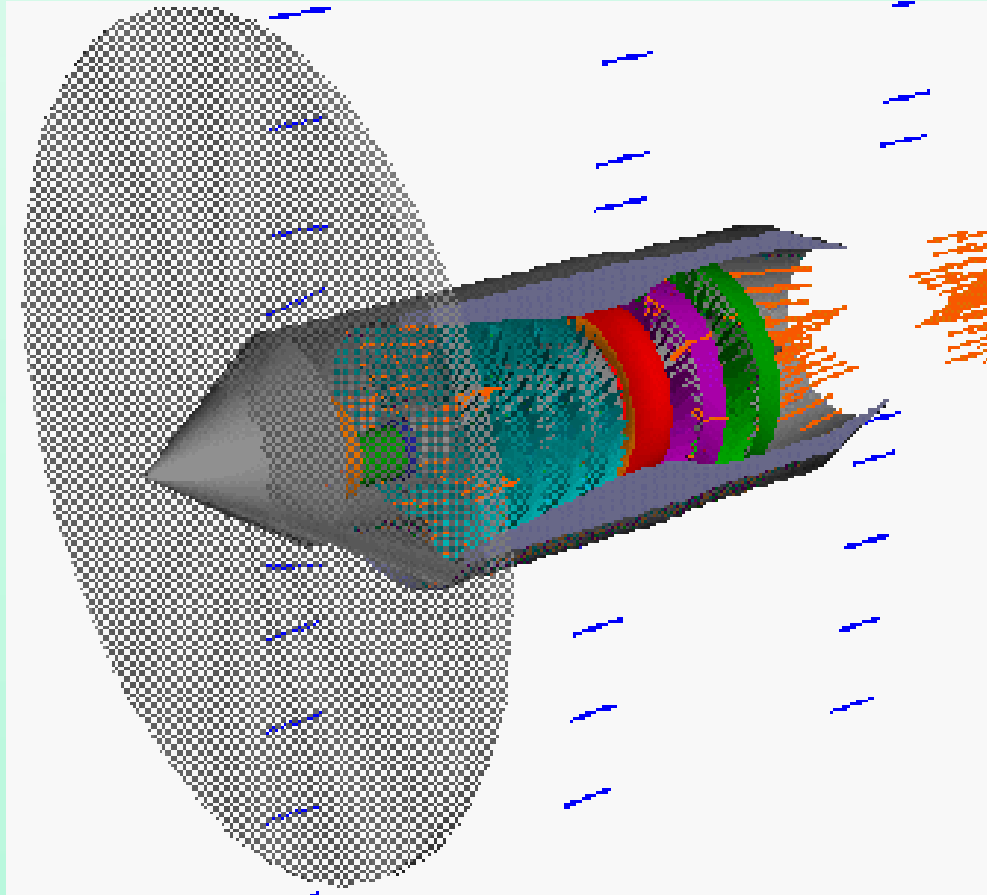

Turbojet Engine



The most common type of air breathing engine apart from turboprop is the turbojet engine.

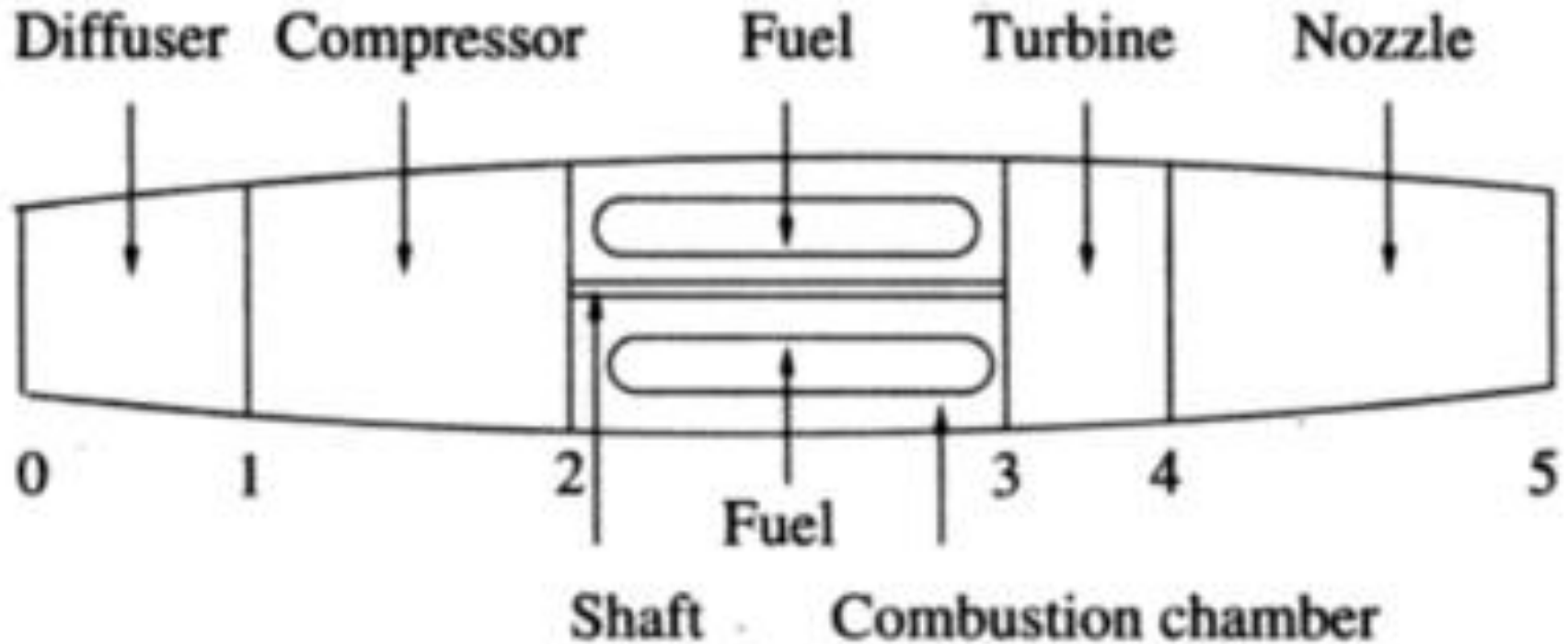

Turbojet Engine - Diffuser



Diffuser converts KE of the entering air into a static pressure by the ram effect.

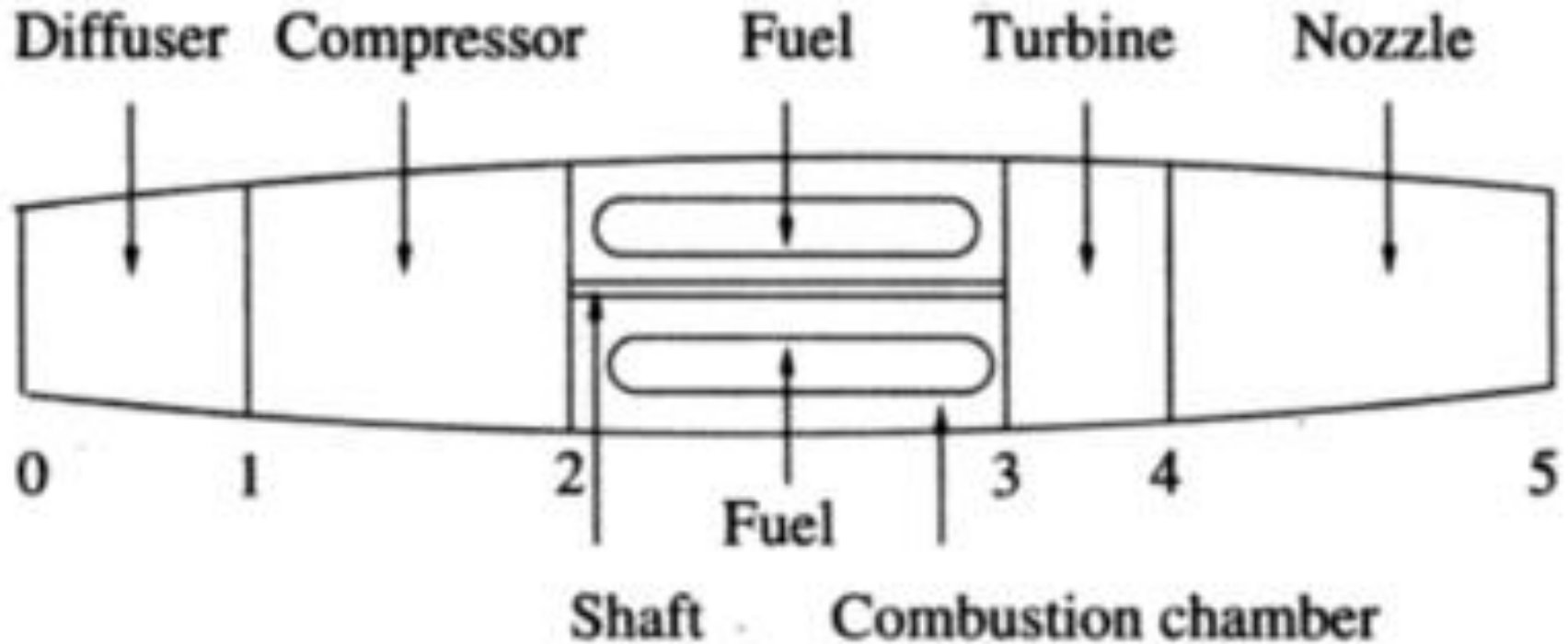

Turbojet Engine - Compressor



Compressor: Centrifugal type or Axial flow type

Engine is capable of operating even under static conditions

However, increase in C_a improves its performance

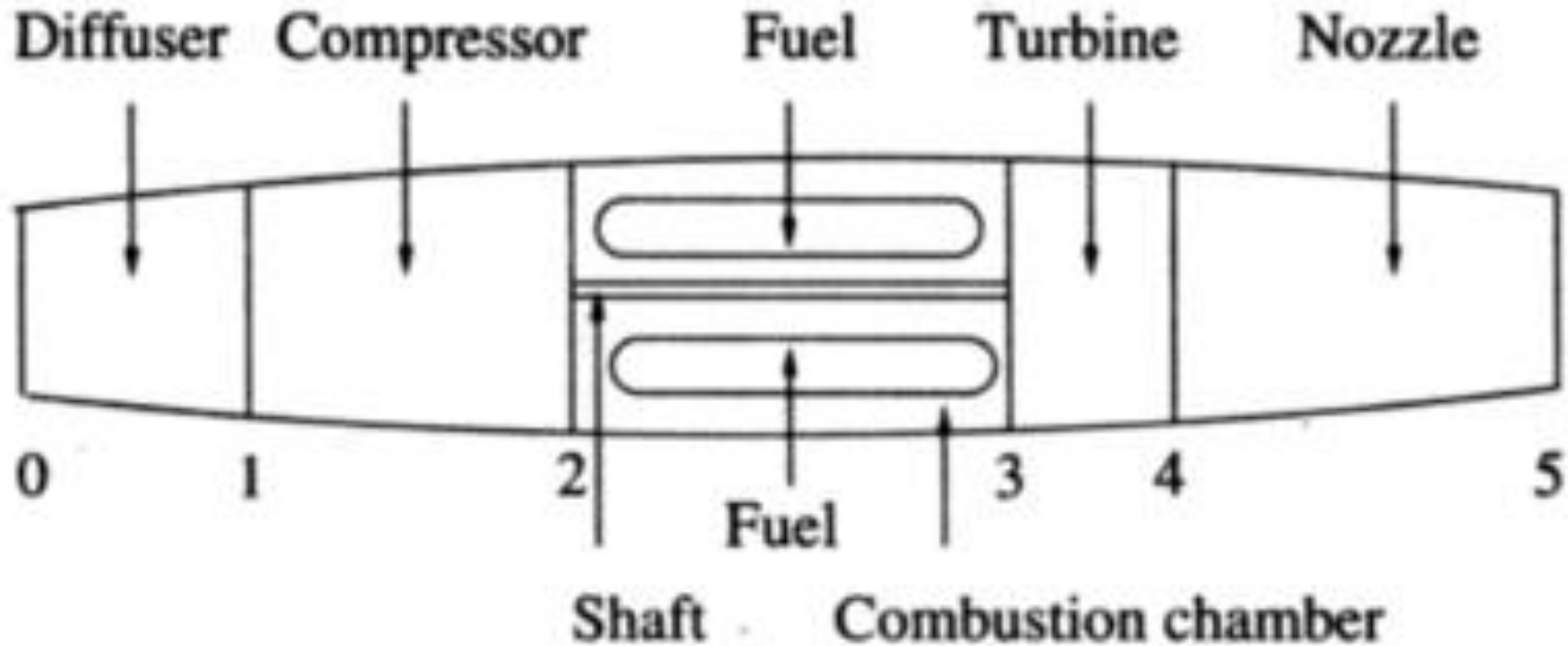

Turbojet Engine - Turbine



Turbine material limitation: f is defined

The exhaust products downstream of turbine still contain oxygen

Afterburner: additional fuel can be burnt

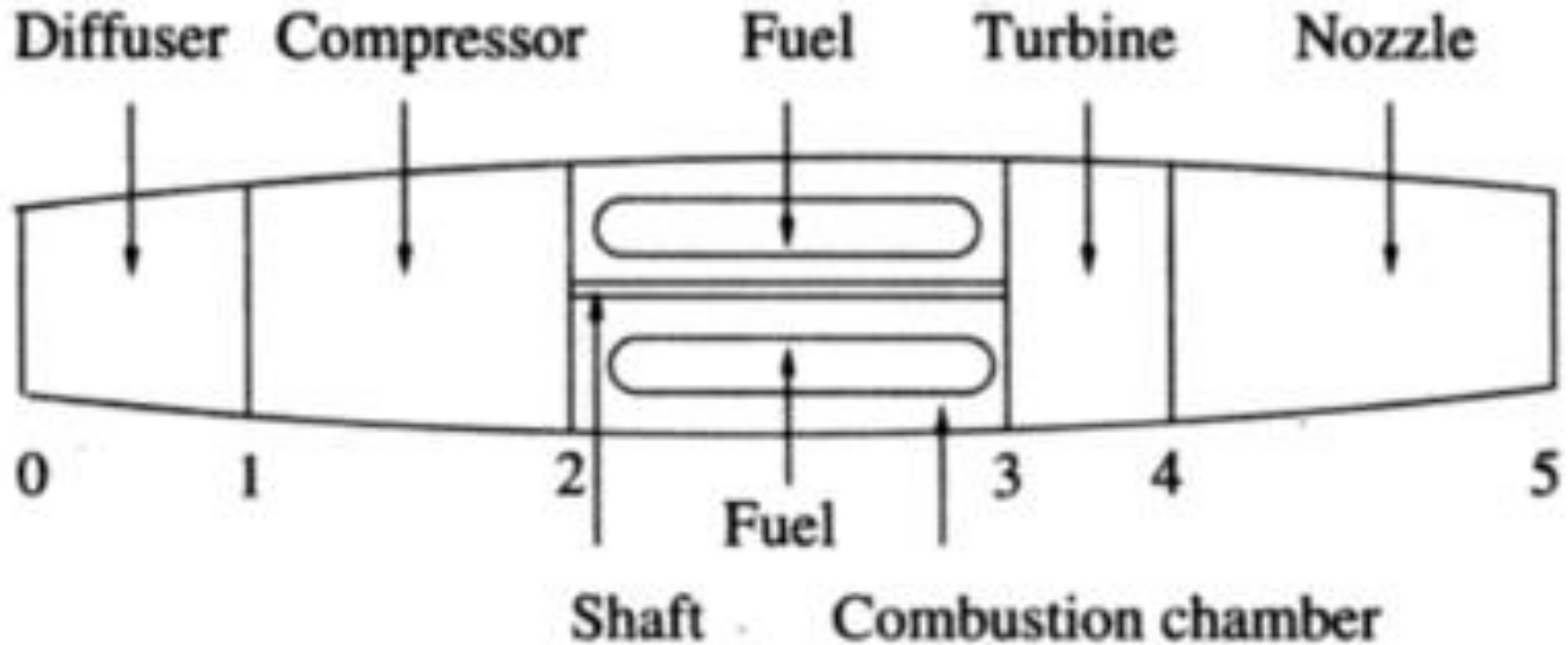

Turbojet Engine - Thermodynamics Cycle



Assumptions:

There is no Δp in CC

γ is constant

$$W_t = W_c$$

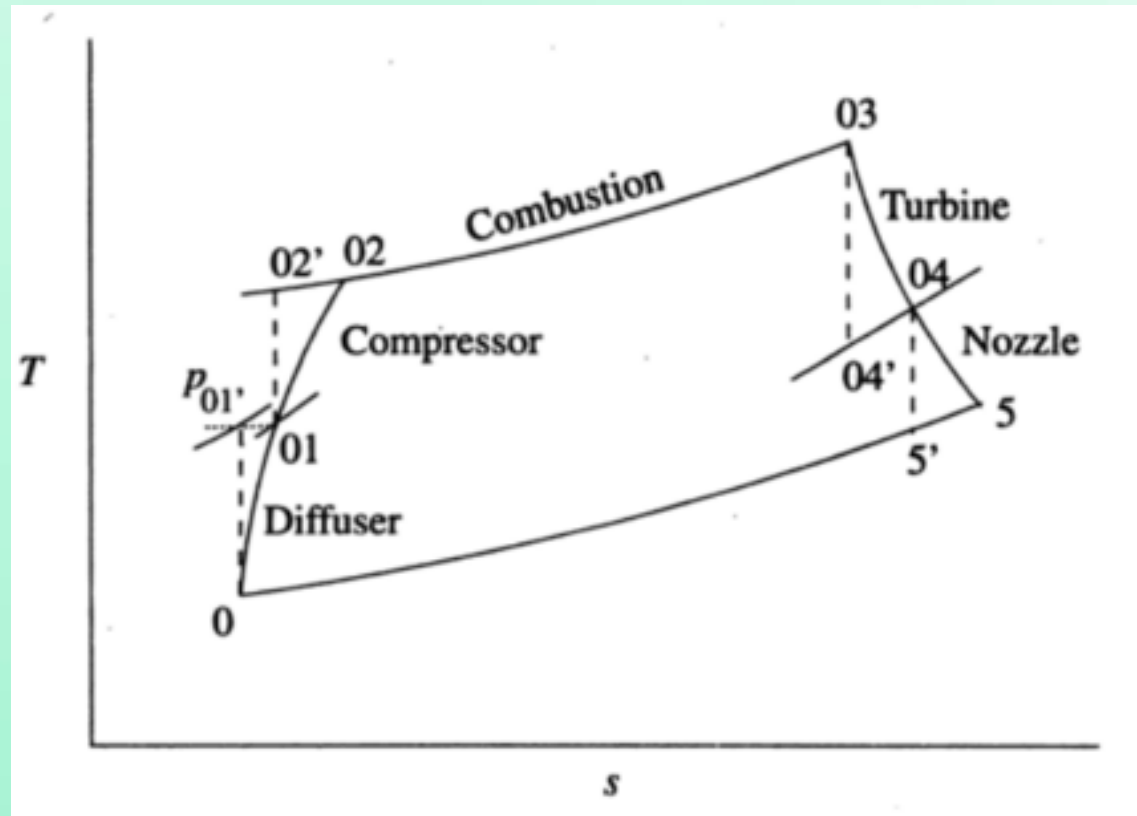

Turbojet Engine - Intake



$$\eta_i = \frac{T_{01'} - T_a}{T_{01} - T_a}$$

$$\frac{p_{01}}{p_a} = \left(\frac{T_{01'}}{T_a} \right)^{\frac{\gamma}{\gamma-1}}$$

$$T_{01}' = T_a + \eta_i \frac{C_a^2}{2C_p}$$

$$M = C/C_s$$

$$C_s = \sqrt{\gamma RT}$$

$$C_p = \gamma R / (\gamma - 1)$$

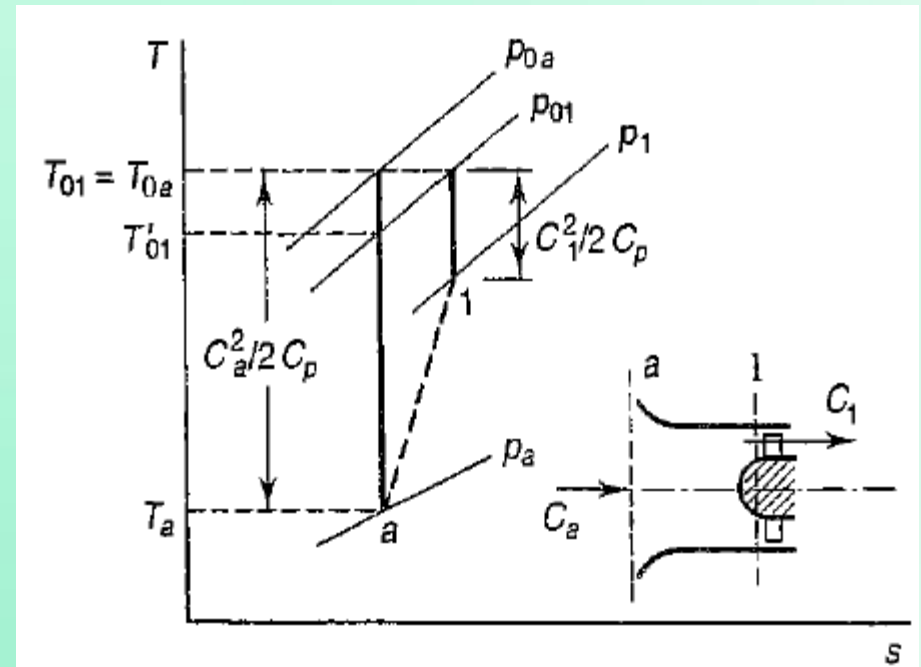

$$\frac{p_{01}}{p_a} = \left(1 + \eta_i \frac{\gamma - 1}{2} M_a^2 \right)^{\frac{\gamma}{\gamma - 1}}$$

$$\frac{T_{01}}{T_a} = 1 + \frac{\gamma - 1}{2} M_a^2$$

Sometimes, it is given as: $\eta_{ram} = \frac{p_{01} - p_a}{p_{0a} - p_a}$

$$\frac{p_{01}}{p_a} = 1 + \eta_{ram} \left\{ \left(1 + \frac{\gamma - 1}{2} M_a^2 \right)^{\frac{\gamma}{\gamma - 1}} - 1 \right\}$$

For a subsonic flow, $\eta_i \simeq \eta_{ram}$

For a supersonic intake, usually *pressure recovery factor* (p_{01}/p_{0a}) is given as a function of Mach number.

$$\frac{p_{01}}{p_a} = \frac{p_{01}}{p_{0a}} \frac{p_{0a}}{p_a}$$

where

$$\frac{p_{0a}}{p_a} = \left(1 + \frac{\gamma - 1}{2} M_a^2 \right)^{\frac{\gamma}{\gamma - 1}}$$

A convergent nozzle is suitable & appropriate for most scenarios.

Check whether p_{04}/p_a is greater than the critical pressure ratio.

For an isentropic expansion the thrust produced is maximum when complete expansion to p_a occurs in the nozzle:

the pressure thrust $A_5(p_5 - p_a)$ arising from incomplete expansion does not entirely compensate for the loss of momentum thrust due to a smaller jet velocity.

At high supersonic speeds the large ram pressure rise in the intake results in a very high nozzle pressure ratio.

p_{04}/p_a is many times larger than the critical pressure ratio

As high as 10-20 times for flight $M= 2-3$

Turbojet Engine – Propelling Nozzle



Isentropic efficiency of the nozzle is an indication of the percentage of total energy converted into velocity energy.

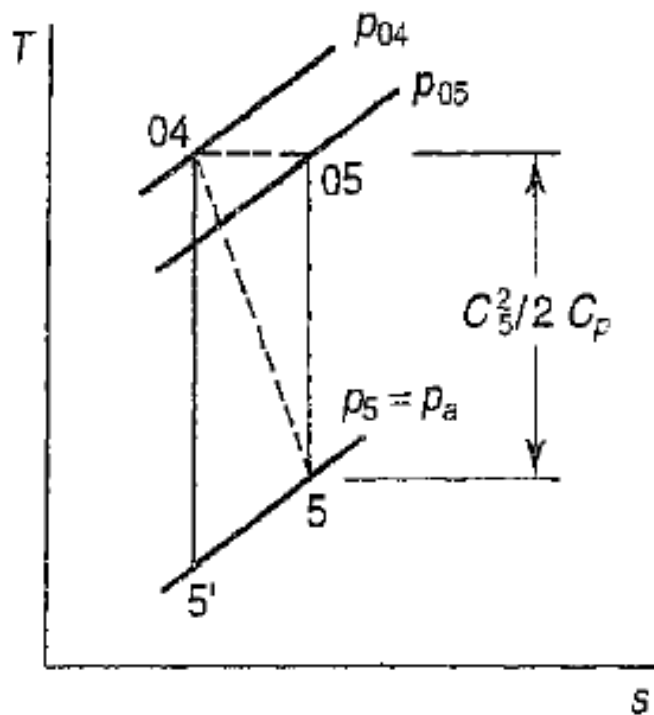

(a) When $\frac{p_{04}}{p_a} < \frac{p_{04}}{p_c}$

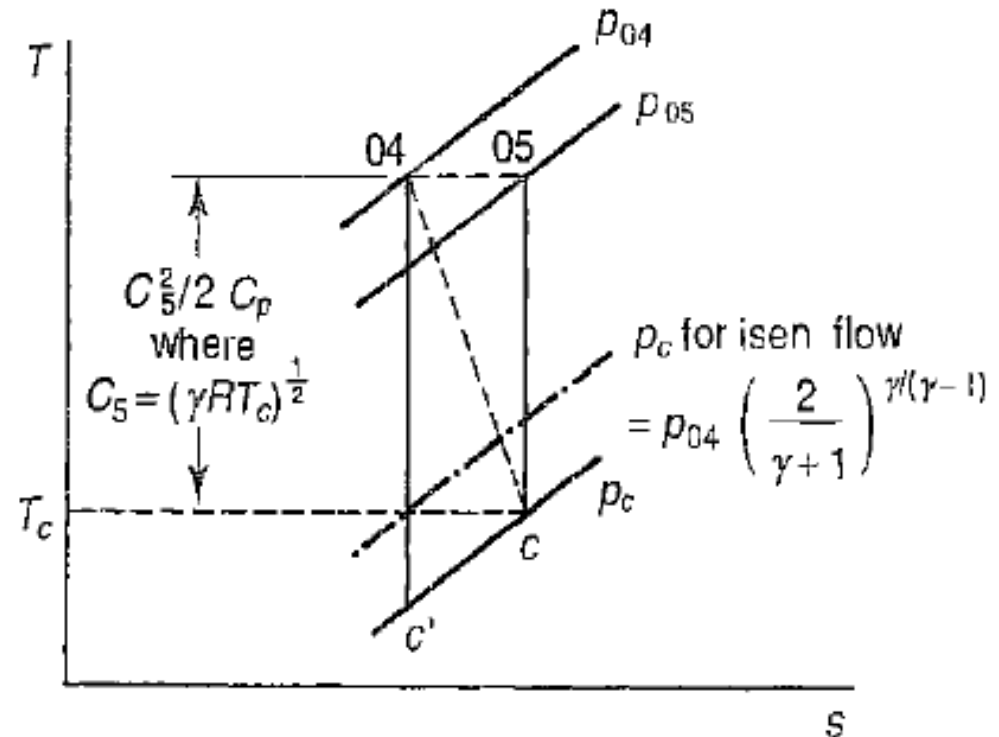

(b) When $\frac{p_{04}}{p_a} > \frac{p_{04}}{p_c}$

$$\eta_{noz} = \frac{T_{04} - T_5}{T_{04} - T_5'}$$

$$T_{04} - T_5 = \eta_{noz} T_{04} \left[1 - \left(\frac{1}{p_{04}/p_5} \right)^{\frac{\gamma-1}{\gamma}} \right]$$

The exit velocity can be given as:

$$T_{04} - T_5 = \frac{C_5^2}{2C_p}$$

The stagnation temperature doesn't change, $T_{04} = T_{05}$

Turbojet Engine – Nozzle Critical Pressure Ratio



For $p_{04}/p_5 < \text{critical ratio}$, p_5 can be substituted by p_a
hence pressure thrust = 0

Above the critical pressure ratio

the nozzle is choked

p_5 remains at p_c

C_5 remains at the sonic value $\sqrt{\gamma RT_5}$

The critical pressure ratio p_{04}/p_c is the pressure ratio p_{04}/p_5 which yields $M_5 = 1$.

The corresponding critical temperature ratio, T_{04}/T_c

$$\frac{T_{04}}{T_5} = \frac{T_{05}}{T_5} = 1 + \frac{C_5^2}{2C_p T_5} = 1 + \frac{\gamma - 1}{2} M_5^2$$

$$\frac{T_{04}}{T_c} = \frac{\gamma + 1}{2}$$

$$T_{c'} = T_{04} - \frac{1}{\eta_{noz}} (T_{04} - T_c)$$

$$\frac{p_c}{p_{04}} = \left(\frac{T_{c'}}{T_{04}} \right)^{\frac{\gamma}{\gamma-1}} = \left[1 - \frac{1}{\eta_{noz}} \left(1 - \frac{T_c}{T_{04}} \right) \right]^{\frac{\gamma}{\gamma-1}}$$

$$\frac{p_{04}}{p_c} = \left[1 - \frac{1}{\eta_{noz}} \left(\frac{\gamma - 1}{\gamma + 1} \right) \right]^{-\frac{\gamma}{\gamma-1}}$$

$$A_5(p_c - p_a)$$

$$A_5 = \frac{m}{\rho_c C_c}$$

ρ_c is obtained from p_c/RT_c and C_c is from $\sqrt{\gamma RT_c}$

$$R = 0.287 \text{ kJ/kg K}$$

Problem: Turbojet



Determination of the specific thrust and *SFC* for a simple turbojet engine, having the following component performance at the design point at which the cruise speed and altitude are $M = 0.8$ and 10000 m.

Compressor ratio = 8

Turbine inlet temperature = 1200 K

Isentropic efficiencies: $\eta_c = 87\%$, $\eta_t = 90\%$, $\eta_i = 93\%$, $\eta_{noz} = 95\%$,

$\eta_{mech} = 99\%$, $\eta_{cc} = 0.98$, $\Delta P_{cc} = 4\%$ comp. deliv. press.

At 10000 m: $p_a = 0.2650$ bar, $T_a = 223.3$ K, $a = 299.5$ m/s

$R = 0.287$ kJ/kg K

Ans: 590 N s/kg, 0.121 kg/h N

Problem: Turbojet



A simple turbojet unit operates with a maximum inlet temperature of 1200 K, a pressure ratio of 4.25:1 and a mass flow of 25 kg/s under design conditions, the following component efficiencies are:

$$\eta_c = 87\%, \eta_{noz} = 9.15\%, \eta_{prop} = 96.5\%, \eta_{mech} = 98.5\%, \Delta P_{cc} = 0.21 \text{ bar}$$

Assume $C_{pa} = 1.005 \text{ kJ/kg K}$, $\gamma_a = 1.4$, $C_{pg} = 1.147 \text{ kJ/kg K}$, $\gamma_g = 1.33$.

Calculate the total design thrust and specific fuel consumption when the unit is stationary and at sea level, where the ambient conditions may be taken as 1 bar and 293 K. Assume air-fuel ratio of 50.

Ans: 16.1 kN, 0.112 kg/N h